

Knife gate valve XV

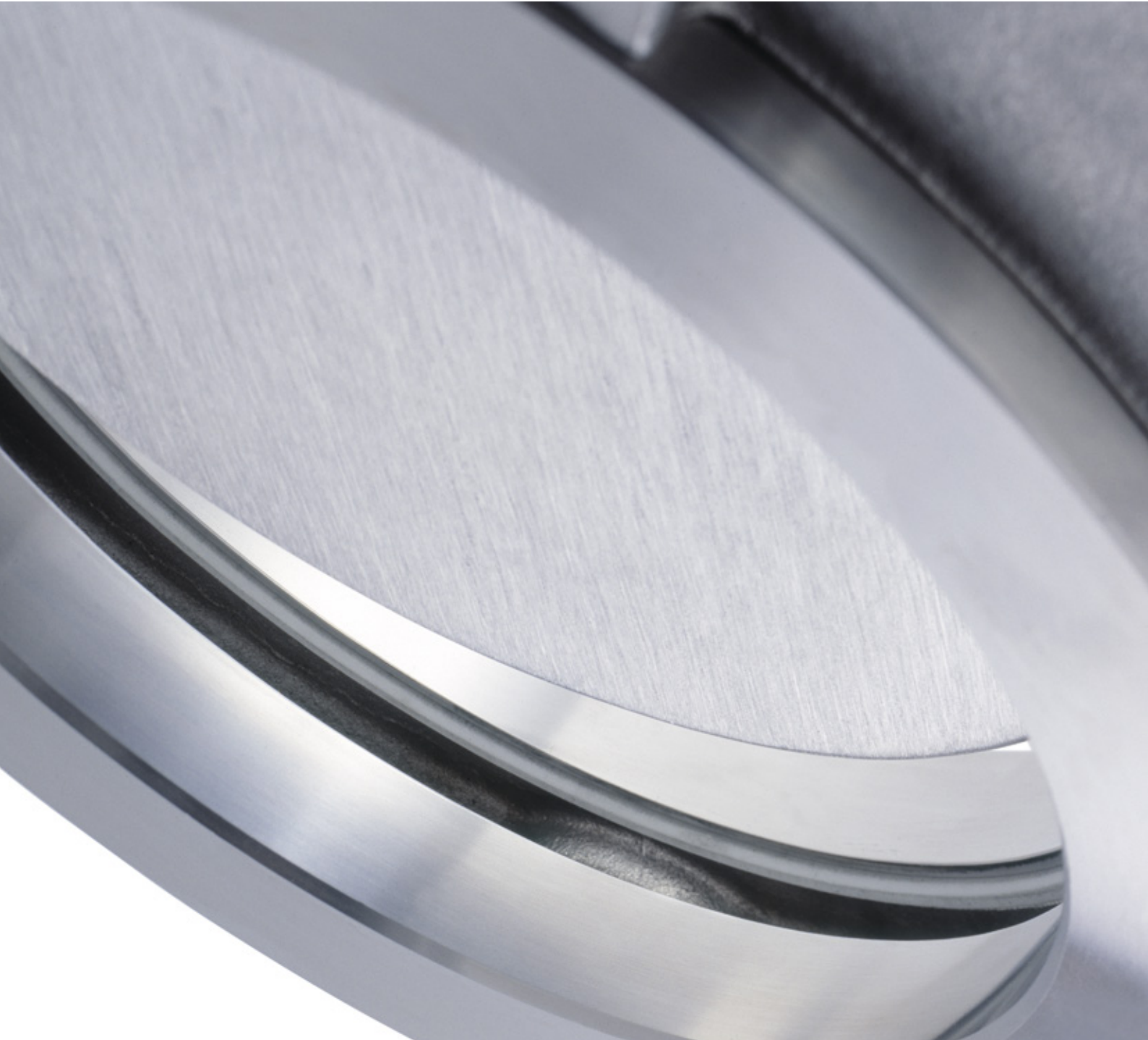

Data is only for informational purpose. All specifications are subject to change without notice.

Knife gate valve XV

Stafsjö's knife gate valve XV gives a secure and tight shut-off, independent of pressure direction. The valve has good flow characteristics and can be used in applications with pulp, biomass and sludge, and the Polyurethane seated version further extend its field of applications to abrasive media such as light slurry.

The XV valve is supplied with valve body, gate, retainer rings and gland in stainless steel. The valve body is available in two versions; fully lugged and semi lugged. The valve comes with the retainer ring system on both sides of the gate, which makes it independent of pressure direction and very easy to maintain. In spite of its relatively low weight and compact design the valve is able to cope with high bi-directional pressures. The gland box is equipped with three layers of Stafsjö's box packing TwinPack™ and a box bottom scraper to secure that no media reaches the surrounding environment.

The top work consists of aluminium beams and stainless steel tie rods, which gives good corrosion resistance and a stable operation. The valve is modular designed and can easily be customized to specific processes requirements. There are several actuator types and accessories to choose from in our standard collection.

The XV valve is designed, manufactured, inspected and tested according to the European Pressure Equipment Directive (PED 97/23/EC) category I and II module A1. The valve is CE marked when it is applicable.



Double retainer ring system makes it bi-directional tight

The retainer ring system on both sides of the gate makes it independent of pressure direction and it also offers simple on-site maintenance.



Self-cleansing function

The gate and the bump in the invert of the valve raise the speed of the media upon closure, forcing the media out of the valve and into the pipe. The valve cleans itself each time it closes.



A first-rate sealing

A gland box supplied with three layers of our TwinPack™, which is specially developed and made for Stafsjö's valves, and a box bottom scraper, secures that no media reaches the surrounding environment.

Design data

Sizes	Flange drilling	Face-to-face dimension	ATEX Design	Corrosion protection
DN 80 - DN 1000	EN 1092 PN10 ASME/ANSI B16.5 Class 150 ASME/ANSI B16.47 Class 150 series A AS 2129 Table D AS 2129 Table E JIS B 2238 10K	Semi lugged version ≤ DN 300: EN 558-1 series 20 Other sizes and versions: Stafsjö manufacturing standard MSS SP-81 TAPPI TIS 405-8	ATEX 94/ 9/EC II cat 3 G/D for zone 2 and 22 on request	Non-corrosive resistant materials are coated in colour RAL5015 acc. to Stafsjö's standard, which fulfill the requirements in EN ISO 12944 class C3.

Other sizes, flange drillings, ATEX zones and corrosion protection on request.

Leakage rate	Pressure test
EN 12266-1:2012 Rate A: no visually detectable leakage is allowed for duration of the test	Pressure tests are performed with water at 20° C according to EN 12266-1:2012. Pressure shell test: 1,5 times maximum allowable working pressure for open valve. Pressure seat tightness test: 1,1 times maximum allowable differential pressure for closed valve.

Maximum working pressure body at 20°C		Maximum differential pressure at 20°C	
DN	bar	DN	bar
<i>Valve equipped with PTFE seats</i>			
80 - 150	16	80 - 350	10
200 - 600	10	400 - 600	6
700 - 900	6	700 - 1000	4
1000	4		
<i>Valve equipped with Polyurethane seats</i>			
80 - 150	16	80 - 300	6
200 - 300	10		

Basic equipment

A. Valve body			
Material	Code	Type	Maximum temperature °C
Stainless steel	(E)	EN 1.4408	400

B. Gate	
Material	Type
Stainless steel	EN 1.4404/AISI 316L

C. Retainer rings	
Material	Type
Stainless steel	EN 1.4408

D. Seats		
Material	Code	Maximum temperature °C
Polyurethane	(U)	90
PTFE with o-ring Nitrile	(P)	100
PTFE with o-ring Viton	(PV)	180

E. Box packing			
Material		Code	Maximum temperature °C
TwinPack™ with scraper in UHMWPE (DN 80 - DN 600)		(TY)	80
<i>Option</i>			
TwinPack™ with PTFE scraper		(TYPS)	260

Actuators

Manual	Code	Automatic	Code
Hand wheel ¹⁾	(HW)	Pneumatic cylinder	(EC)
Chain wheel ²⁾	(CW)	Electric motor	(EM)
		Hydraulic cylinder ²⁾	(MH)

¹⁾ For recommended size, see page 5 column E.

²⁾ For recommended size, see separate data sheet.

Double-acting pneumatic cylinder			Electric motor (AUMA multi-turn)		
DN valve	EC type	Force at 5 bar (kN)	DN valve	AUMA type	Attachment
80 - 150	EC100	3,5	80 - 150	SA 07.2	F10/A
200 - 300	EC160	9,0	200 - 250	SA 07.6	F10/A
350 - 500	EC200	14,1	300 - 600	SA 10.2	F10/A
600 - 700	EC250	22,1	700 - 900	SA 14.2	F14/A
800 - 900	EC320	36,2	1000	SA 14.6	F14/A
1000	EC400	57,8			

The table above gives recommended cylinder sizes at normal operation with 5 bar air pressure. For other operating conditions, please contact Stafsjö or your local representative for advice.

Electric motors are mounted according to standard ISO 5210. The table above gives recommended motor sizes at normal operation. For other operating conditions, please contact Stafsjö or your local representative for advice.

The actuators are described in separate data sheets. For advice and information on other actuators or on ATEX-classified ones, please contact Stafsjö or your local representative.

Specify the Stafsjö valve

Stafsjö's valves are modular designed and they can easily be customized with gate, seat and box packings according to media and requirements, as well for actuators and accessories. Below are examples of how you can specify your Stafsjö valve. Further information is available on www.stafsjo.com.

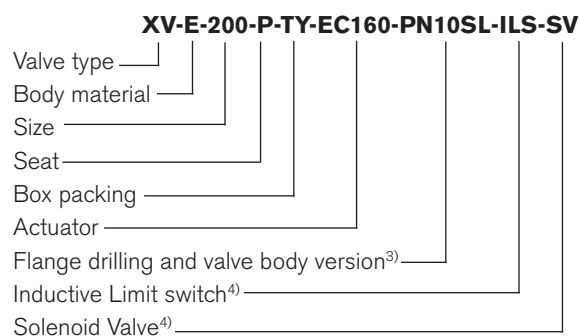
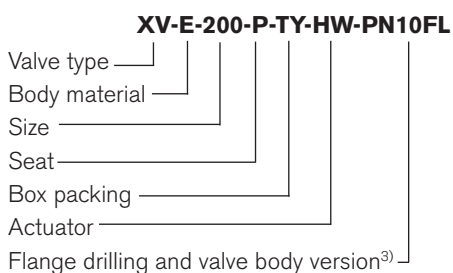

³⁾ Type of valve body must be specified, i.e. fully lugged (FL) or semi lugged (SL)

⁴⁾ All electronics must be specified in detail.

One piece valve body: DN 80 - DN 600

Two piece valve body: DN 700 - DN 1000

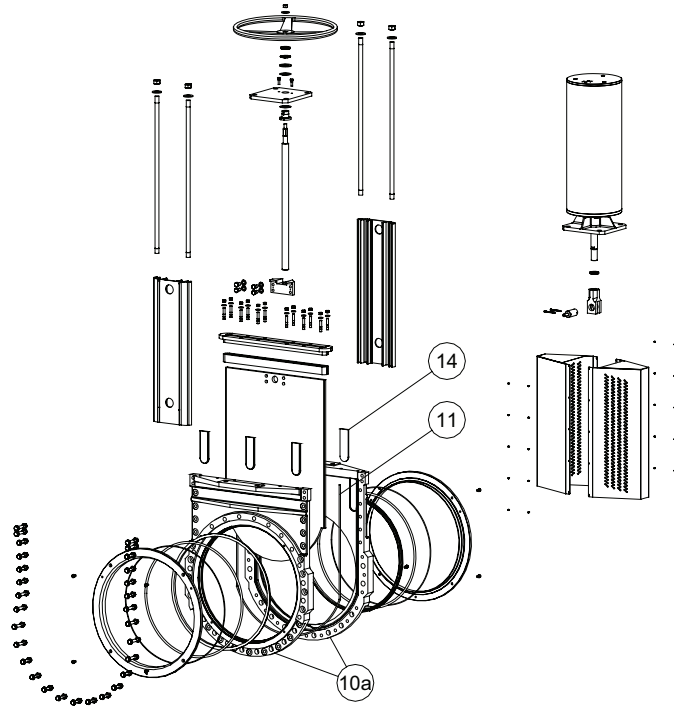
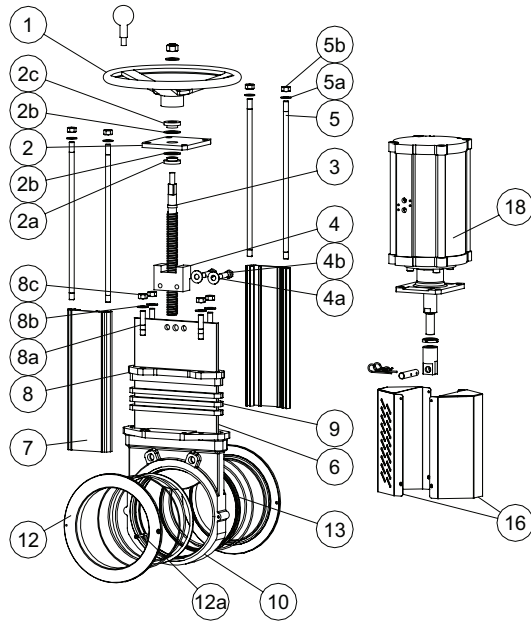

Part list

Pos.	Part	Material (Type)
1	Hand wheel	Coated cast iron Ø 200 - Ø 315 (EN-JL1040/GG25), ≥ Ø 400 (EN-JL1030/GG20)
2	Yoke	Stainless steel (EN 1.4301)
2a	Bearing	Brass (CuZn39Pb3)
2b	Slide washer	POM
2c	Bearing	Brass (CuZn39Pb30)
3	Stem	Stainless steel (EN 1.4016)
4	Stem nut	Brass (CW603N)
4a	Washer	Stainless steel (A2)
4b	Screw	Stainless steel (A2)
5	Tie rod	Stainless steel (EN 1.4301)
5a	Washer	Stainless steel (A2)
5b	Nut	Stainless steel (A2)
6	Gate	See basic equipment B
7	Beam	Aluminium (EN AW-6063-T6)

Pos.	Part	Material (Type)
8	Gland	Stainless steel (EN 1.4408)
8a	Stud bolt	Stainless steel, zinc coated (A2)
8b	Washer	Stainless steel (A2)
8c	Nut	Stainless steel, zinc coated (A2)
9 ⁵⁾	Box packing	See basic equipment E
10/a	Valve body	See basic equipment A
11	Body gasket	PTFE
12	Retainer ring	See basic equipment C
12a	Locking screw	Stainless steel (A2)
13 ⁵⁾	Seat	See basic equipment D
14	Guiding pads	PTFE
16	Gate guard, not for HW	Stainless steel (EN 1.4301)
18	Cylinder	See data sheet for EC

⁵⁾ Recommended spare parts

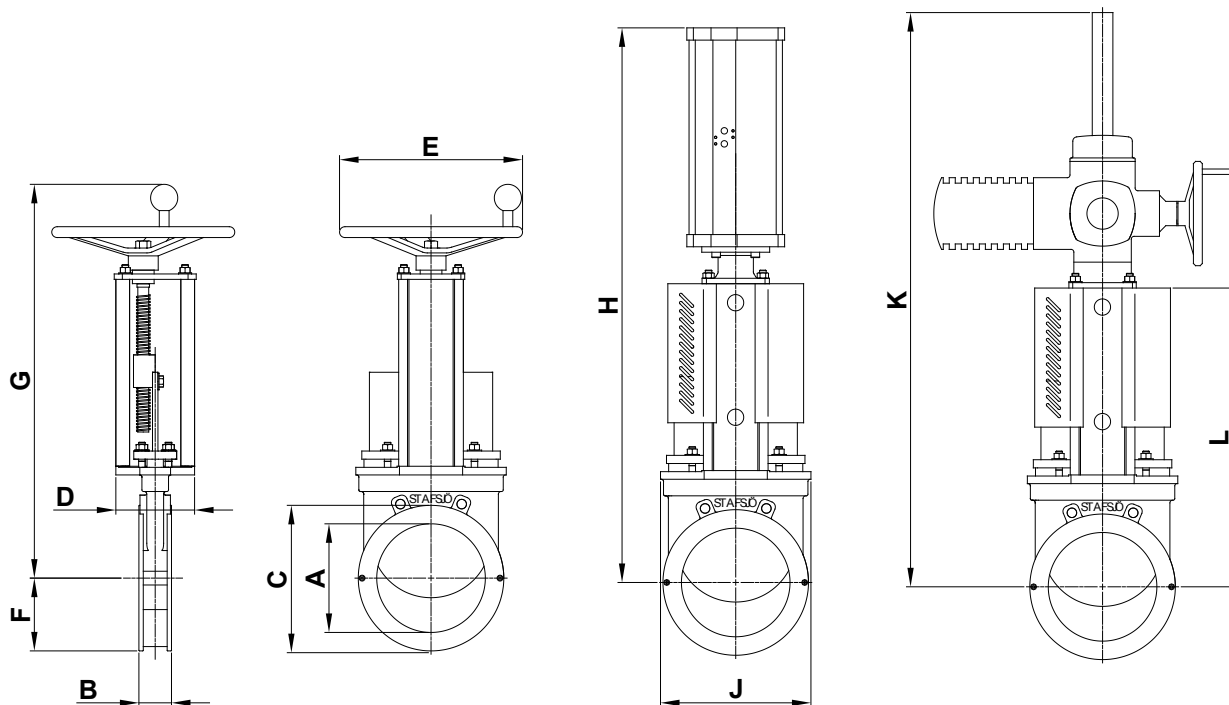

Main dimensions for valve with semi lugged valve body

Dimension (mm)												
DN	A	B	C	D	E	F	G	H	J	K	L	Weight ⁶⁾
80	80	46	138	80	200	69	444	552	140	690	314	8
100	100	52	158	80	200	79	482	590	158	728	352	10
125	125	56	188	80	250	94	523	681	188	769	393	13
150	150	56	212	80	250	106	567	725	212	813	437	15
200	200	60	269	145	315	135	691	912	277	868	546	30
250	250	68	322	145	315	161	785	1111	331	994	640	41
300	300	78	372	145	315	186	879	1205	382	1149	734	57
350	350	78	432	175	400	216	1021	1508	437	1308	841	-
400	400	89	481	175	400	241	1116	1603	488	1453	936	-
500	500	114	586	250	520	302	1342	1939	603	1770	1152	-
600	600	114	686	260	635	343	1546	2230	735	2076	1356	-
700	680	128	800	320	635	450	1650	2571	902	2382	1527	-
800	780	128	901	320	635	500	1866	2888	1002	2697	1742	-
900	880	128	1001	320	-	570	-	3079	1132	3022	1933	-
1000	980	150	1108	320	-	635	-	3384	1258	3312	2123	-

⁶⁾ Weight in kg for valve equipped with hand wheel.

Main dimensions are only for information. Contact Stafsjö for certified drawings.

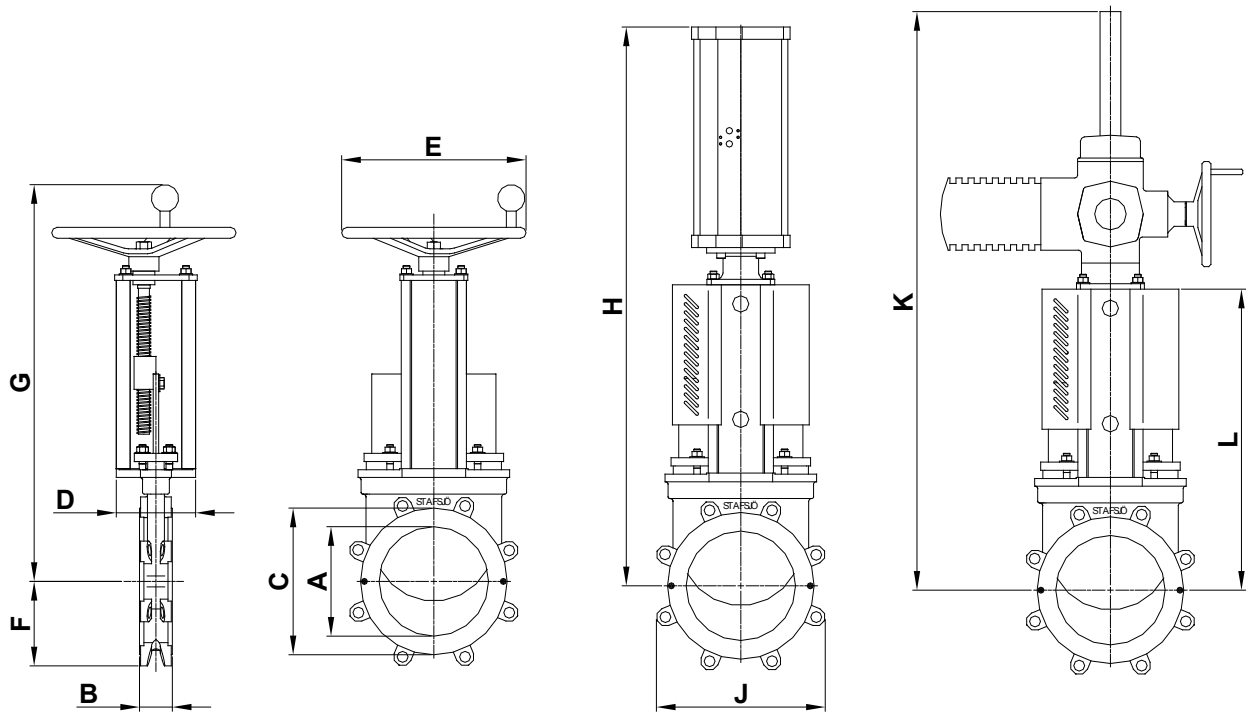

Main dimensions for fully lugged valve body

Dimension (mm)														
Size	A	B	C ⁹⁾	C ¹⁰⁾	C ¹¹⁾	D	E	F	G	H	J	K	L	Weight ⁷⁾
80	80	50	123	123	128	80	200	89	444	552	177	690	314	10
100	100	52	154	154	158	80	200	101	482	590	202	728	352	13
125	-	-	-	-	188	-	-	-	-	-	-	-	-	-
150	150	56	212	209	212	80	250	128	567	725	255	813	437	16
200	200	60 ⁸⁾	268	266	268	145	315	155	691	912	309	868	546	30
250	250	68	322	322	322	145	315	195	785	1111	389	994	640	48
300	300	78	372	372	372	145	315	229	879	1205	457	1149	734	63
350	350	78	432	432	432	175	400	256	1021	1508	512	1308	841	100
400	400	89	481	481	481	175	400	288	1116	1603	576	1453	936	135
450	450	89	531	531	531	200	520	309	1263	1843	618	1591	1056	170
500	500	114	586	586	586	250	520	340	1342	1939	681	1770	1152	200
600	600	114	686	686	686	260	635	400	1546	2230	799	2076	1356	370

⁷⁾ Weight in kg for valve equipped with hand wheel.

⁸⁾ Face-to-face (B) is 70 mm for valve with PTFE seats and flange drilling according to ASME/ANSI B16.5 and B16.47 Class 150 series A.

⁹⁾ Dimensions for valve with flange drilling according to EN 1092 PN10 or AS Table D.

¹⁰⁾ Dimension for valve with flange drilling according to AS Table E.

¹¹⁾ Dimensions for valve with flange drilling according to ASME/ANSI B16.5 and B16.47 Class 150 series A.

Main dimensions are only for information. Contact Stafsjö for certified drawings.

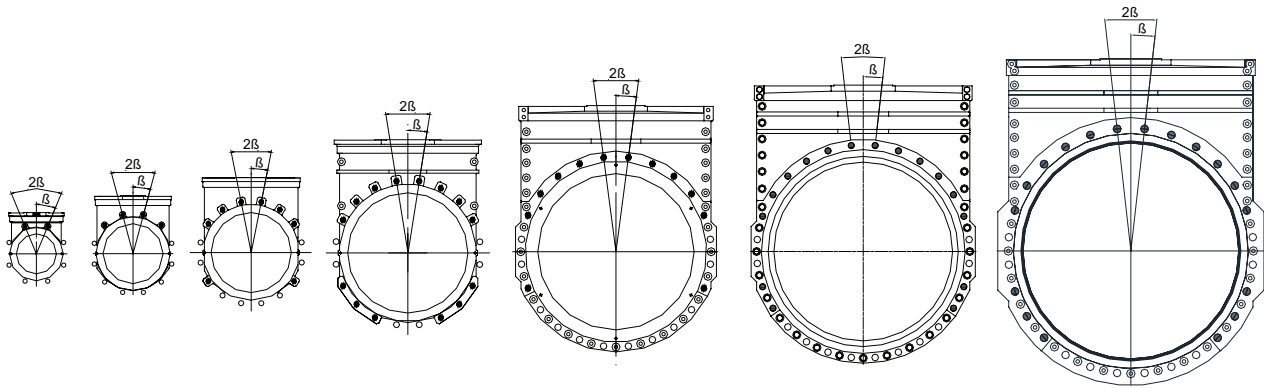

DN 80 - DN 250 - DN 350 - DN 500 - DN 600 DN 700 - DN 800 DN 900 DN 1000
 DN 200 DN 300 DN 400

Flange drilling according to EN 1092 PN 10

Flange drilling information for valve with semi lugged valve body (mm)

Size	80	100	125	150	200	250	300	350	400	500	600	700	800	900	1000
Outside flange diameter	200	220	250	285	340	395	445	505	565	670	780	895	1015	1115	1230
Bolt circle diameter	160	180	210	240	295	350	400	460	515	620	725	840	950	1050	1158
Number of throughgoing bolts (○)	6	6	6	6	6	6	8	8	8	6	6	12	12	12	10
Number of tapped holes on each side (●)	2	2	2	2	2	4	4	8	8	14	14	12	12	16	18
Bolt size	M16	M16	M16	M20	M20	M20	M20	M20	M24	M24	M27	M27	M30	M30	M33
β°	22,5	22,5	22,5	22,5	22,5	15	15	11,25	11,25	9	9	7,5	7,5	6,43	6,43
Screw lengths ¹²⁾	10	12	14	12	13	15	19	19	21	27	27	31	31	31	33

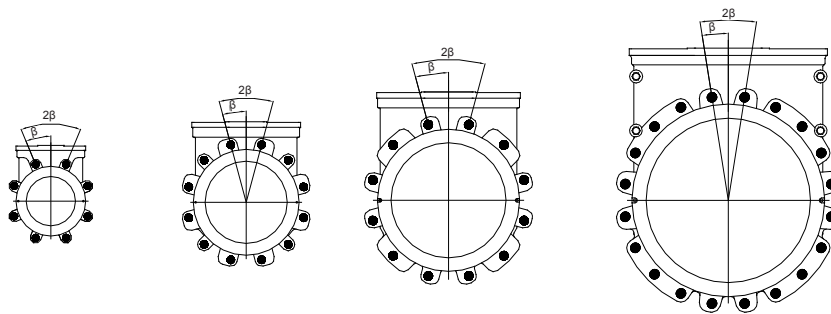

DN 80 - DN 200 DN 250 - DN 300 DN 350 - DN 400 DN 500 - DN 600

Flange drilling according to EN 1092 PN 10

Flange drilling information for valve with fully lugged valve body (mm)

Size	80	100	125	150	200	250	300	350	400	500	600
Outside flange diameter	200	220	250	285	340	395	445	505	565	670	780
Bolt circle diameter	160	180	210	240	295	350	400	460	515	620	725
Number of throughgoing bolts (○)	-	-	-	-	-	-	-	-	-	-	-
Number of tapped holes on each side (●)	8	8	8	8	8	12	12	16	16	20	20
Bolt size	M16	M16	M16	M20	M20	M20	M20	M20	M24	M24	M27
β°	22,5	22,5	22,5	22,5	22,5	15	15	11,25	11,25	9	9
Screw lengths ¹²⁾	13	14	14	14	15	17	21	21	24	32	29

¹²⁾ Add the value with the thickness of the pipe flanges, the washers and the estimated thickness of the gasket.

○ Throughgoing holes

● Tapped holes

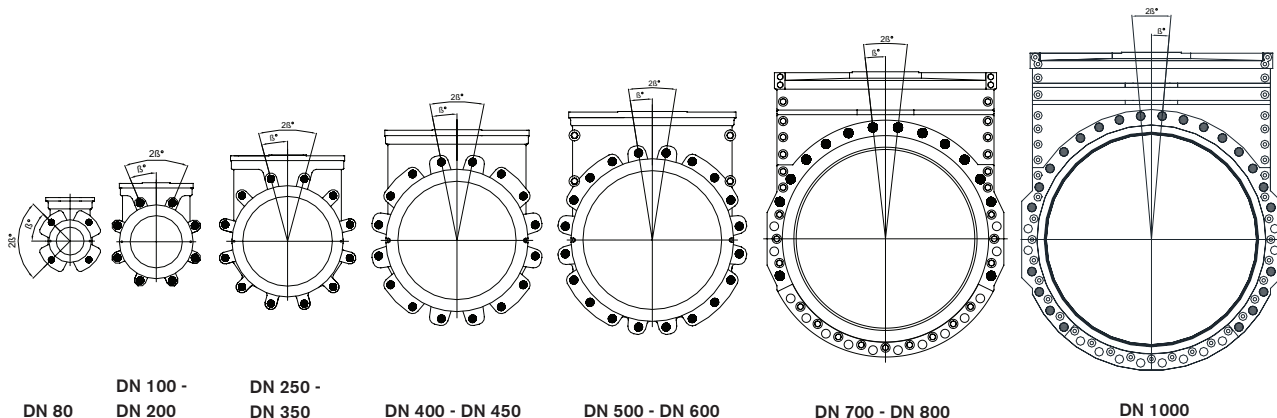

DN 80 DN 100 - DN 200 DN 250 - DN 350 DN 400 - DN 450 DN 500 - DN 600 DN 700 - DN 800 DN 1000

Flange drilling according to ASME/ANSI B16.5 and B16.47 Class 150 series A

Flange drilling information for valve with fully lugged valve body \leq DN 600 and semi lugged on \geq DN 700 (mm)																
Size	80	100	125	150	200	250	300	350	400	450	500	600	700	800	900	1000
Outside flange diameter	190,5	228,6	254	279,4	342,9	406,4	482,6	533	597	635	699	813	927	1060	OR	1289,1
Bolt circle diameter	152,4	190,5	215,9	241,3	298,5	362	431,8	476	540	578	635	749	863	978	OR	1200,2
Number of throughgoing bolts (○)	-	-	-	-	-	-	-	-	-	-	-	-	14	14	OR	12
Number of tapped holes on each side (●)	4	8	8	8	8	12	12	12	16	16	20	20	14	14	OR	24
Bolt size (UNC)	5/8-11	5/8-11	3/4-10	3/4-10	3/4-10	7/8-9	7/8-9	1-8	1-8	11/8-7	11/8-7	11/4-7	11/4-7	11/2-6	OR	11/2-6
β°	45	22,5	22,5	22,5	22,5	15	15	15	11,25	11,25	9	9	6,5	6,5	OR	5
Screw lengths ¹²⁾	13	14	14	14	20	17	21	21	24	23	32	29	34	34	OR	33

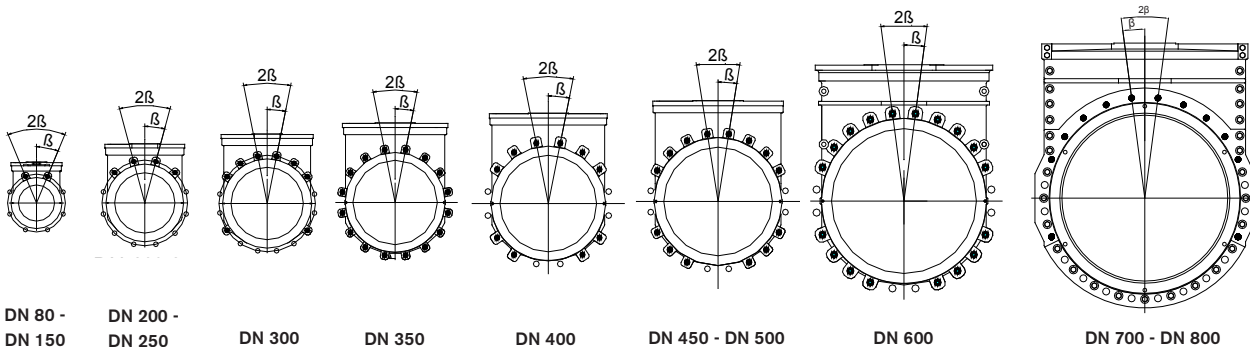

DN 80 - DN 150 DN 200 - DN 250 DN 300 DN 350 DN 400 DN 450 - DN 500 DN 600 DN 700 - DN 800

Flange drilling according to JIS B 2238 10K

Flange drilling information for valve with semi lugged valve body (mm)																
DN	80	100	125	150	200	250	300	350	400	450	500	600	700	800	900	1000
Outside flange diameter	185	210	250	280	330	400	445	490	550	620	675	795	895	1015	OR	OR
Bolt circle diameter	150	175	210	240	290	355	400	445	510	565	620	730	840	950	OR	OR
Number of throughgoing bolts (○)	6	6	6	6	8	8	8	-	6	6	6	6	12	12	OR	OR
Number of tapped holes on each side (●)	2	2	2	2	4	4	8	16	10	14	14	18	12	12	OR	OR
Bolt size	M16	M16	M20	M20	M20	M22	M22	M22	M24	M24	M24	M30	M30	M30	OR	OR
β°	22,5	22,5	22,5	22,5	15	15	11,25	11,25	11,25	9	9	7,5	7,5	7,5	OR	OR
Screw lengths ¹²⁾	11	12	15	13	13	16	20	20	22	22	24	24	31	31	OR	OR

¹²⁾ Add the value with the thickness of the pipe flanges, the washers and the estimated thickness of the gasket.

○ Throughgoing holes

● Tapped holes

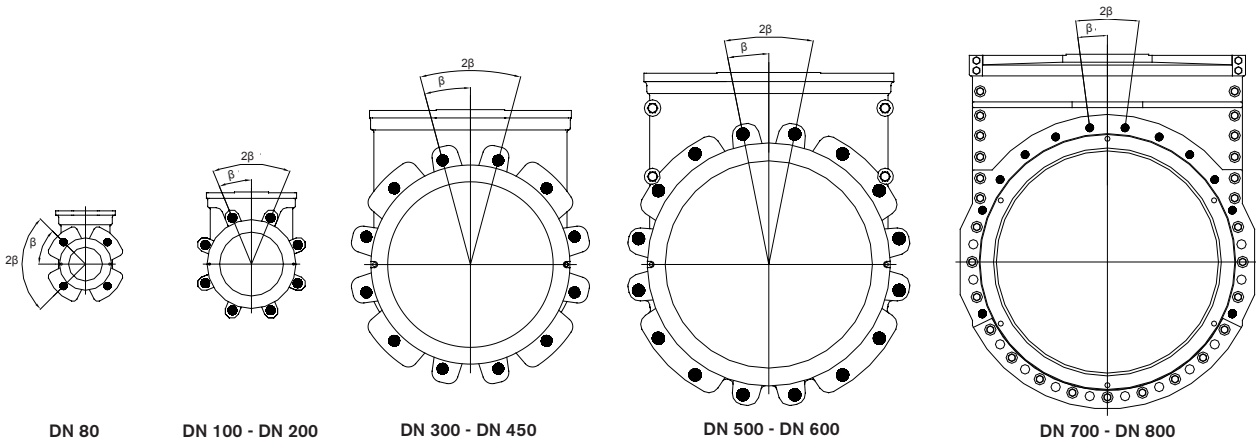

Flange drilling according to AS Table D

Flange drilling information for valve with fully lugged valve body \leq DN 600 and semi lugged on \geq DN 700 (mm)															
Size	80	100	150	200	250	300	350	400	450	500	600	700	800	900	1000
Outside flange diameter	185	215	280	335	405	455	525	580	640	705	825	910	1060	OR	OR
Bolt circle diameter	146	178	235	292	356	406	470	521	584	641	756	845	984	OR	OR
Number of throughgoing bolts (°)	-	-	-	-	-	-	-	-	-	-	-	10	10	OR	OR
Number of tapped holes on each side (•)	4	4	8	8	8	12	12	12	12	16	16	10	10	OR	OR
Bolt size	M16	M16	M16	M16	M20	M20	M24	M24	M24	M24	M27	M30	M33	OR	OR
β°	45	45	22,5	22,5	22,5	15	15	15	15	11,25	11,25	9	9	OR	OR
Screw lengths ¹²⁾	13	14	14	15	17	21	21	21	23	32	29	34	34	OR	OR

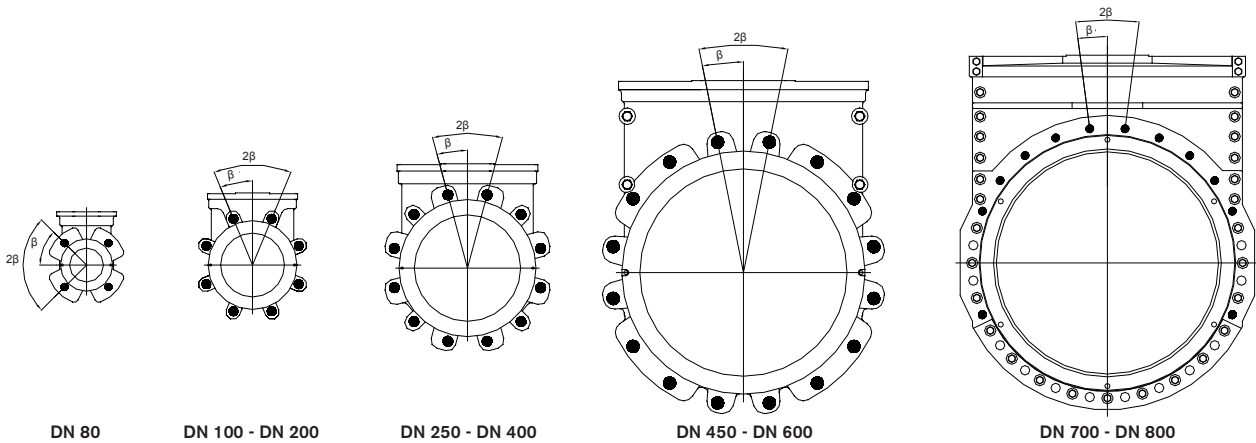

Flange drilling according to AS Table E

Flange drilling information for valve with fully lugged valve body \leq DN 600 and semi lugged on \geq DN 700 (mm)															
Size	80	100	150	200	250	300	350	400	450	500	600	700	800	900	1000
Outside flange diameter	185	215	280	335	405	455	525	580	640	705	825	910	1060	OR	OR
Bolt circle diameter	146	178	235	292	356	406	470	521	584	641	756	845	984	OR	OR
Number of throughgoing bolts (°)	-	-	-	-	-	-	-	-	-	-	-	10	10	OR	OR
Number of tapped holes on each side (•)	4	8	8	8	12	12	12	12	16	16	16	10	10	OR	OR
Bolt size	M16	M16	M20	M20	M20	M24	M24	M24	M24	M24	M30	M30	M33	OR	OR
β°	45	22,5	22,5	22,5	15	15	15	15	11,25	11,25	11,25	9	9	OR	OR
Screw lengths ¹²⁾	13	14	14	15	17	21	21	24	23	32	29	34	34	OR	OR

¹²⁾ Add the value with the thickness of the pipe flanges, the washers and the estimated thickness of the gasket.

° Throughgoing holes

• Tapped holes

Further information is available on www.stafsjo.com

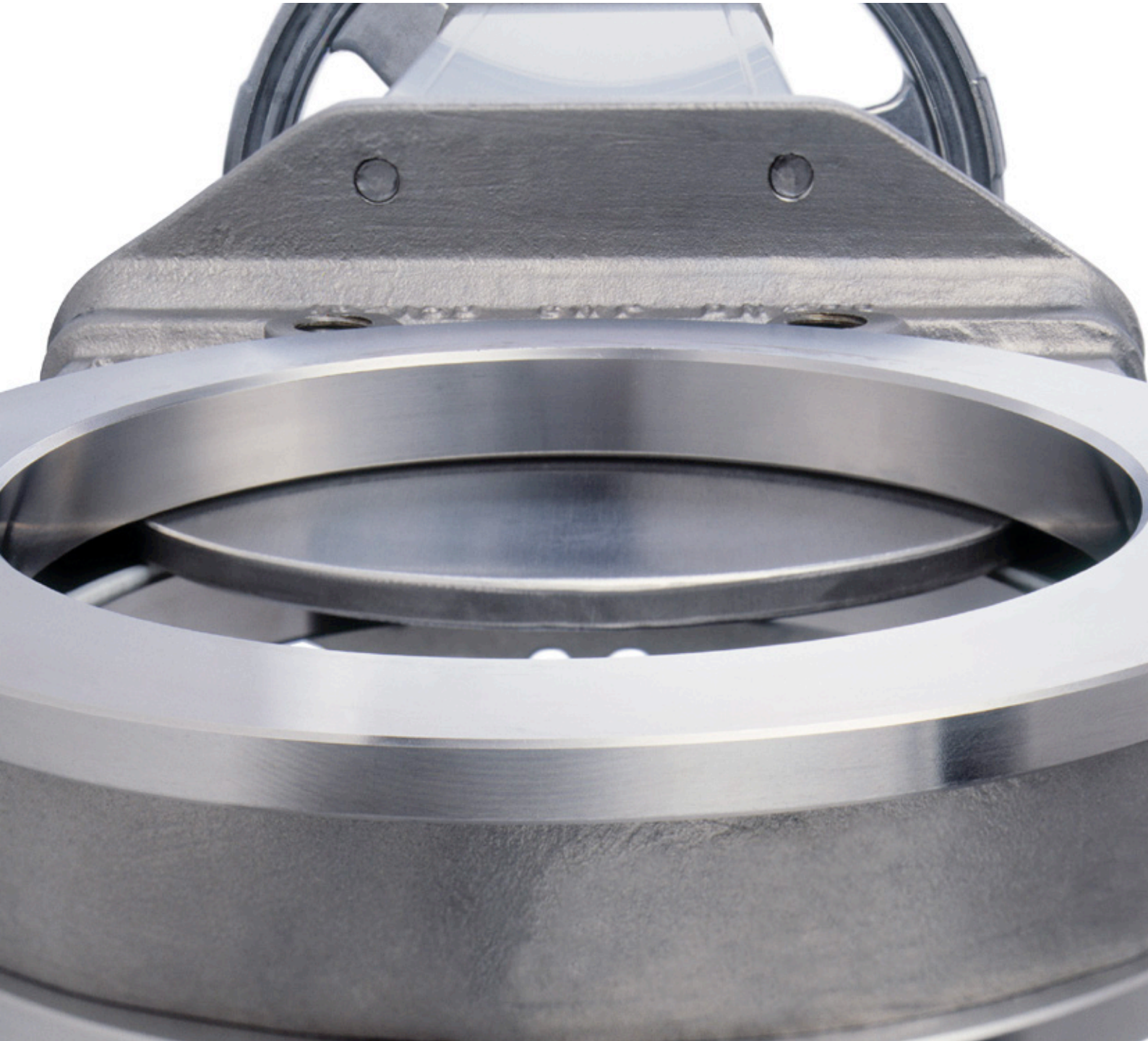

Globally active. Locally represented.

AFRICA South Africa: Valve & Automation (Pty) Ltd, **ASIA** China: EBRO ARMATUREN (BEIJING) CO., LTD, India: Ebro Armaturen India Pvt. Ltd, Indonesia: Contromatic Prima Mandiri PT, Japan: SKC Co. Ltd, Malaysia: Precision Control SdnBnd, Philippines: EBRO ARMATUREN (PHILIPPINES) INC., Thailand: EBRO VALVES (Trading) Co. Ltd., Vietnam: EBRO VALVES (Thailand) Co., Ltd, **AUS-TRALIA/OCEANIA** Australia: EBRO ARMATUREN Pacific PTY. LTD, New Zealand: H.J.Asmuss&Co.Ltd **EUROPE** Austria: EBRO ARMATUREN GmbH, Belgium: V.C.T. - Valve & Connector Technology n.v., Denmark: Valtor Industri A/S, Finland: Tecalemit Flow Oy, France: EBRO ARMATUREN, Germany: EBRO ARMATUREN Gebr. Bröer GmbH, Great Britain: EBRO Valves Ltd, Hungary: EBRO ARMATUREN Kft, Ireland: ESI Technologies Ltd., Iceland: Hédinn HF, Italy: EBRO VALVOLE SRL, The Netherlands: EBRO VALVES B.V., Norway: BAGGES AS, Poland: EBRO ARMATUREN GmbH, Portugal: AxFlow Comércio de Aquipamentos LDA, Russia: LesBumMash Ltd, Roitech and Sevkom, Spain: EBRO ARMATUREN ESPAÑA, S.L., Switzerland: EBRO Armaturen Est. & Co. KG, Sweden: Stafsjö Valves AB and Ahlsell Sverige AB, Turkey: EBRO ARMATUREN Otomasyon Sistemleri San ve Tic Ltd. Sti, Ukraine: EBRO ARMA-TUREN GmbH Representative office Kiev **NORTH AMERICA** Canada: Armour Valve Ltd, USA: EBRO ARMATUREN USA Inc. **SOUTH AMERICA** Argentina: ESCO ARGENTINA SA, Brazil: ELAN Equipamentos Industriais LTDA, Chile: Ebro Stafsjö Valves Chile Ltd
For other countries, please contact us directly.

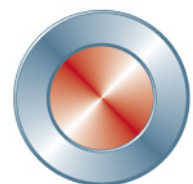

Stafsjö
SINCE 1666